

**CHIPONE**

集创北方

**ICN2053**

**(16-Channel PWM Constant Current LED Sink Driver)**

## Description

The ICN2053 is a 16-channel PWM constant current sink output LED driver for 1:32 time multiplexing applications. The constant-current value of all 16 channels is set by a single external resistor.

ICN2053 converts serial input data into each pixel's gray scale of the output port by a 16-bit shift register. ICN2053 detects individual LED open errors without extra components. ICN2053 also integrated pre-charge circuit for ghosting reduction, LED protect circuit.

The ICN2053 exploits current precision controlling technology, which makes error between ICs less than  $\pm 2.0\%$ , and error between channels less than  $\pm 2.0\%$ .

## Features

- ✧ 16 constant-current output channels
- ✧ Support time-multiplexing for 1~32 scans
- ✧ Output current setting range:  
0.5~25mA×16@V<sub>DD</sub>=5V constant current output  
0.5~18mA×16@V<sub>DD</sub>=4.2V constant current output  
0.5~10mA×16@V<sub>DD</sub>=3.3V constant current output
- ✧ Current accuracy  
Between channel :<  $\pm 2.0\%$  (Max.)  
Between ICs :<  $\pm 2.0\%$  (Max.)
- ✧ 8 bit current gain: 12.5%~200%
- ✧ Fast response of output current:  
 $\overline{OE}$  (min):20ns@V<sub>DD</sub>=5V
- ✧ Data transfer frequency: f<sub>MAX</sub>=35MHz(Max)
- ✧ Power supply voltage: V<sub>DD</sub>=3.3~5V
- ✧ Operating Temperature: -40°C to +85°C
- ✧ Output current equation

$$I_{out} = \frac{9.23}{R_{EXT}}$$

- ✧ Pre-charge for ghosting reduction
- ✧ LED open detection
- ✧ Enhanced Circuit for Caterpillar Cancelling
- ✧ Low-gray scale enhancement
- ✧ Integrating LED protection circuit

## Package

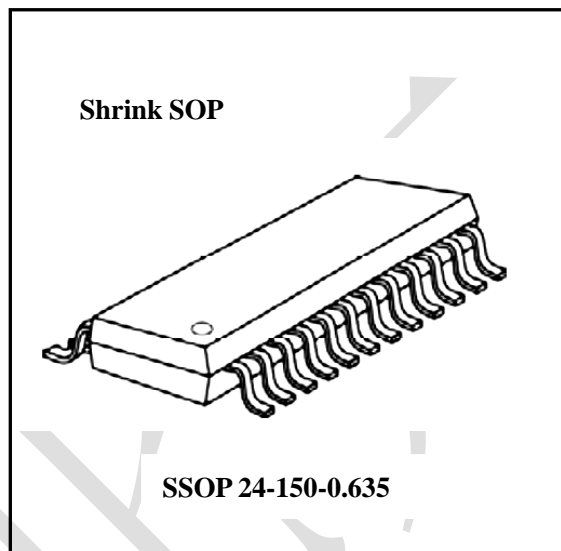

**ICN2053**

## Pin Configuration

SSOP24-P-150-0. 635

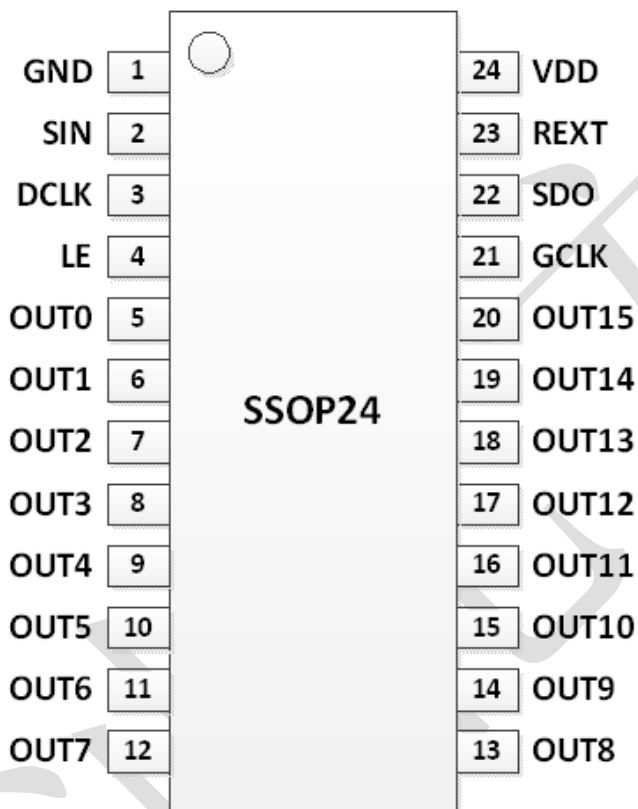

ICN2053(SSOP24)		
Pin No.	Pin Name	Function
1	GND	Power Ground
2	SIN	Serial data input
3	DCLK	Clock input terminal for data shift and command information
4	LE	Data transfer command input pin
5~20	OUT0 ~ OUT15	Constant current output
21	GCLK	The reference clock input pin for PWM gray scale control
22	SDO	Serial data output
23	REXT	Constant-current value setting .Connection to an external resistor to GND
24	VDD	Power-supply voltage

## ICN2053 Block Diagram

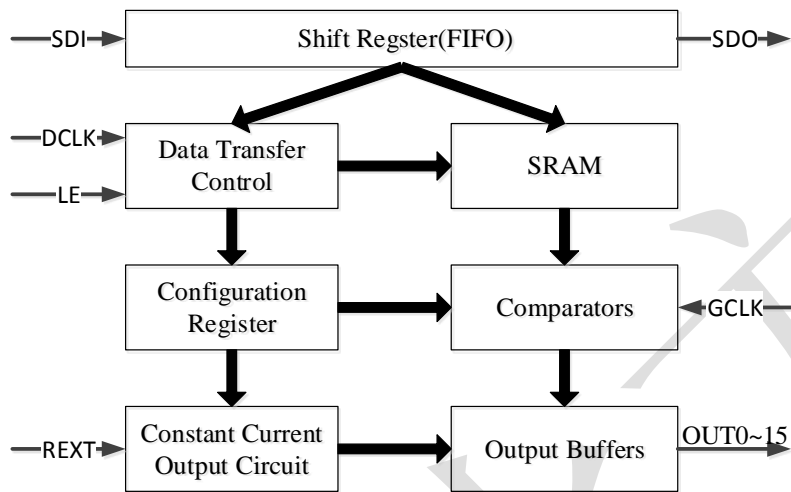

## I/O Equivalent Circuits

### 1. GCLK, SDI, LE

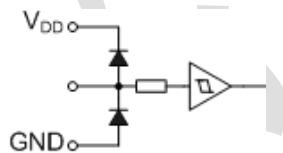

### 2. DCLK

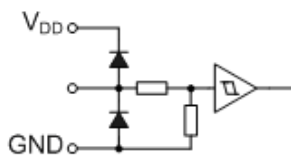

### 3. SDO

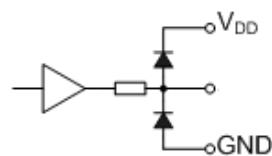

**Control Command**

Command Name	Number of DCLK Rising Edge when LE is High	Description
DATA_LATCH	1	Transfer Serial data to buffers
WR_DBG	2	Write Debug Register
VSYNC	3	Vertical Synchronal signal
WR_CFG1	4	Write Configuration Register 1
RD_CFG1	5	Read Configuration Register 1
WR_CFG2	6	Write Configuration Register 2
RD_CFG2	7	Read Configuration Register 2
WR_CFG3	8	Write Configuration Register 3
RD_CFG3	9	Read Configuration Register 3
WR_CFG4	10	Write Configuration Register 4
RD_CFG4	11	Read Configuration Register 4
EN_OP	12	Enable All Output Channels
DIS_OP	13	Disable All Output Channels
PRE_ACT	14	Pre-Active command

**Data Transfer Order**

Data Order	Line	Channel
1	Line 1	Channel 15 (OUT15)
2		Channel 14 (OUT14)
.....		.....
16		Channel 0 (OUT0)
17	Line 2	Channel 15 (OUT15)
18		Channel 14 (OUT14)
.....		.....
32		Channel 0 (OUT0)
.....		
497	Line 32	Channel 15 (OUT15)
498		Channel 14 (OUT14)
.....		.....
512		Channel 0 (OUT0)

**Timing Diagram**

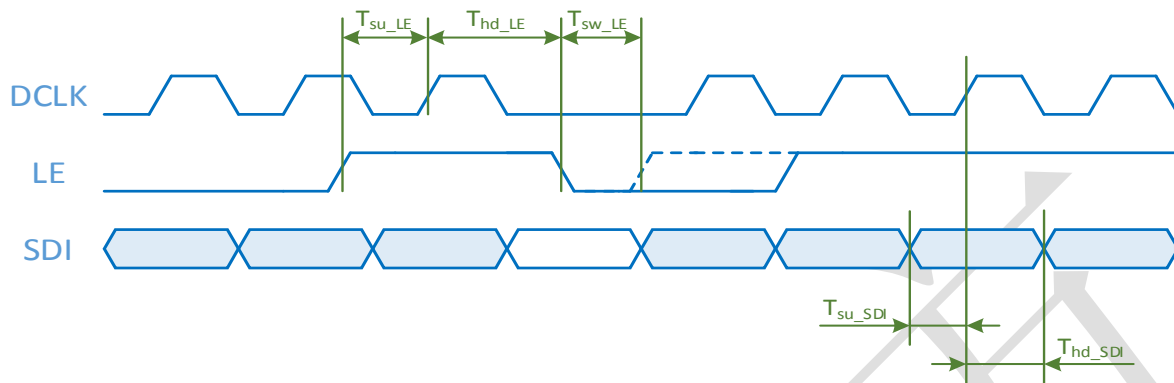

**Maximum Rating** ( $T_a=25^{\circ}\text{C}$ )

Characteristics		Symbol	Rating	Unit
Supply Voltage		$V_{DD}$	0~6.0	V
Output Current		$I_O$	25	mA
Input Voltage		$V_{IN}$	-0.4~ $V_{DD}+0.4$	V
Output voltage		$V_{OUT}$	11V	
Clock Frequency		$F_{CLK}$	35	MHz
GND Terminal Current		$I_{GND}$	+1000	mA
Power Dissipation (On PCB, 25°C)	DN-type	$P_D$	3.19	W
Thermal Resistance	DN-type	$R_{th(j-a)}$	39.15	°C/W
Operating Temperature		$T_{opr}$	-40 ~ 85	°C
Storage Temperature		$T_{stg}$	-55 ~ 150	°C

**Electrical Characteristics** (Unless otherwise specified,  $V_{DD}=4.5\sim 5.5\text{V}$ ,  $T_a=25^{\circ}\text{C}$ )

Characteristics	Symbol	Test circuit	Test Conditions	Min	Typ	Max	Unit
High level logic output voltage	$V_{OH}$	1	$I_{OH}=-1\text{mA}$ , SDO	$V_{DD}-0.4$	-	$V_{DD}$	V
Low level logic output voltage	$V_{OL}$	1	$I_{OH}=+1\text{mA}$ , SDO	-	-	0.4	V
High level logic input voltage	$V_{IH}$		$0.7*V_{DD}$	-	$V_{DD}$	V	
Low level logic input voltage	$V_{IL}$	3	GND	-	$0.3*V_{DD}$	V	
High level logic input current	$I_{IH}$	2	$V_{IN}=V_{DD}$ , SDI,CLK,LE,GCLK	-	-	1	μA
Low level logic input current	$I_{IL}$	1	$V_{IN}=\text{GND}$ SDI,CLK,LE,GCLK	-1	-	-	μA
Power supply current	$I_{DD1}$	4	Rext=Open, Out off	-	4.5	6.0	mA
	$I_{DD2}$	4	Rext=1.24kΩ, Out off	-	6.0	7.0	mA
Constant current error	$\Delta I_O$	5	0.5mA~25mA	-	±1.0	±2.0	%
Constant current power supply voltage regulation	% $V_{DD}$	5	$V_{DD}=4.5\sim 5.5\text{V}$ , $R_{EXT}=3\text{k}\Omega$ , $\overline{\text{OUT0}}\sim \overline{\text{OUT15}}$	-	±0.1	-	%/V
Constant current output voltage regulation	% $V_{OUT}$	5	$V_O=0.6\sim 3.0\text{V}$ , $R_{EXT}=3\text{k}\Omega$ , $\overline{\text{OUT0}}\sim \overline{\text{OUT15}}$	-	±0.1		%/V
Pull-down resistor	$R_{DOWN}$	2	DCLK	100	200	400	kΩ

**Test Circuit**

**Test Circuit1: High level logic input voltage/Low level logic input voltage**

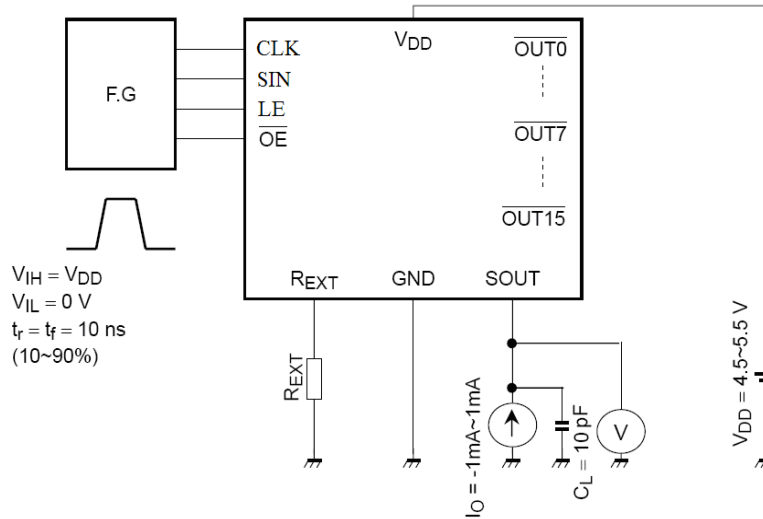

**Test Circuit2: High level logic input current/Pull-down resistor**

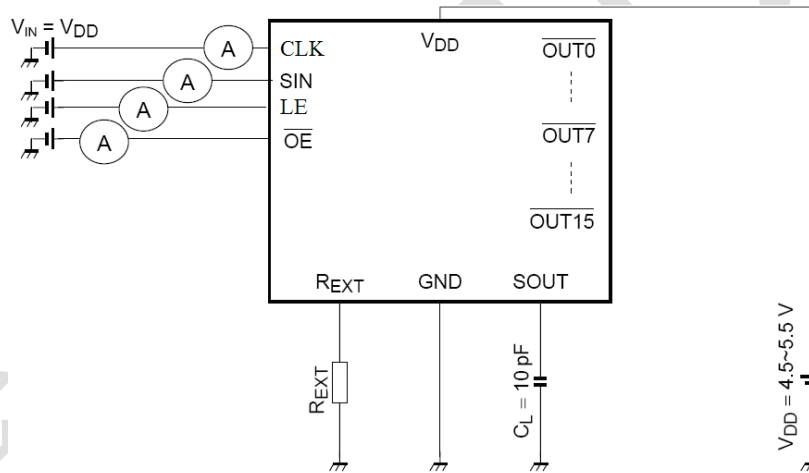

**Test Circuit3: Low level logic input current/Pull-up resistor**

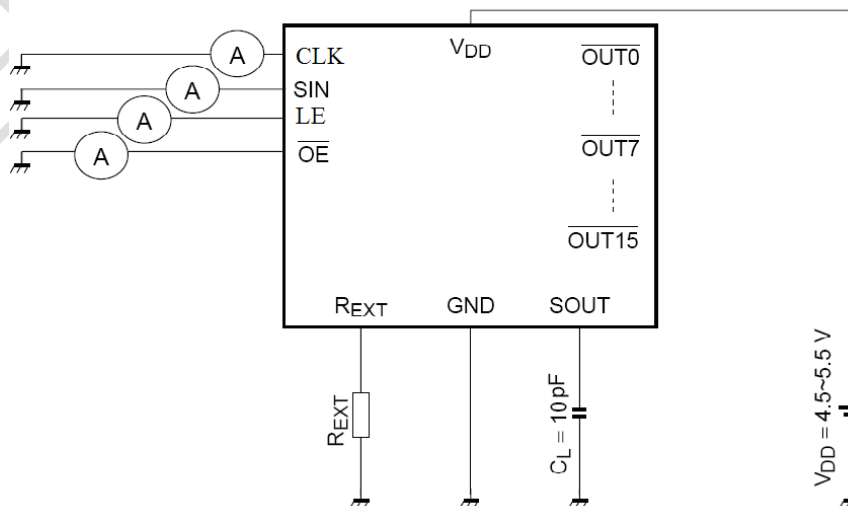



**Test Circuit4: Power supply current**

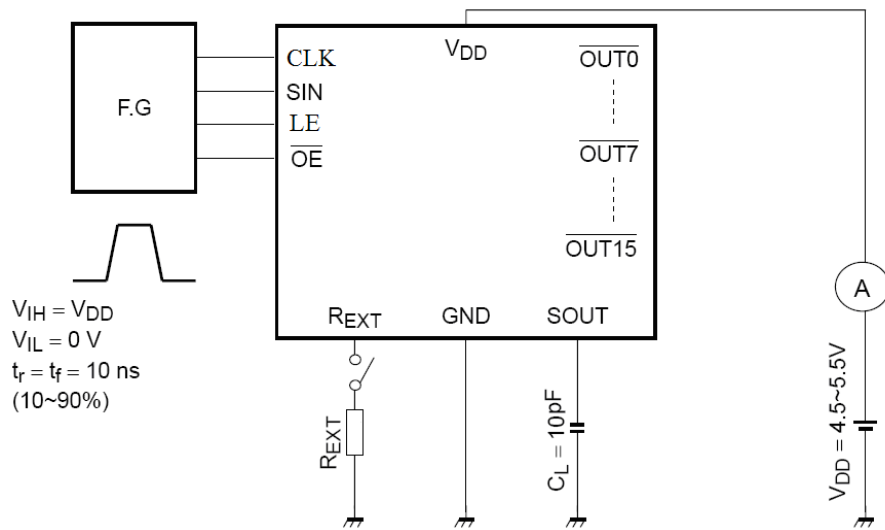

**Test Circuit5: Constant current output/Output OFF leak current/Constant current error  
Constant current power supply voltage regulation/Constant current output voltage regulation**

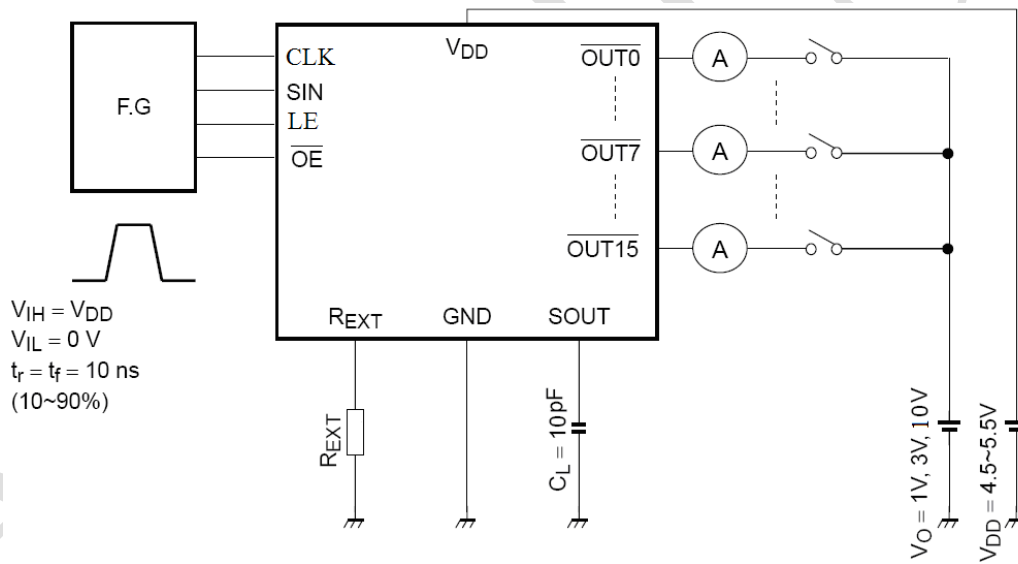

## Application Information

ICN2053 exploits current precision controlling technology, and provides nearly no current variations from channel to channel and from IC to IC.

- 1) The maximum current variation between channels is less than  $\pm 2.0\%$ , and that between ICs  $< \pm 2.0\%$ .
- 2) The current characteristic of output stage is flat, and can be kept constant regardless of the variations of LED forward voltage.

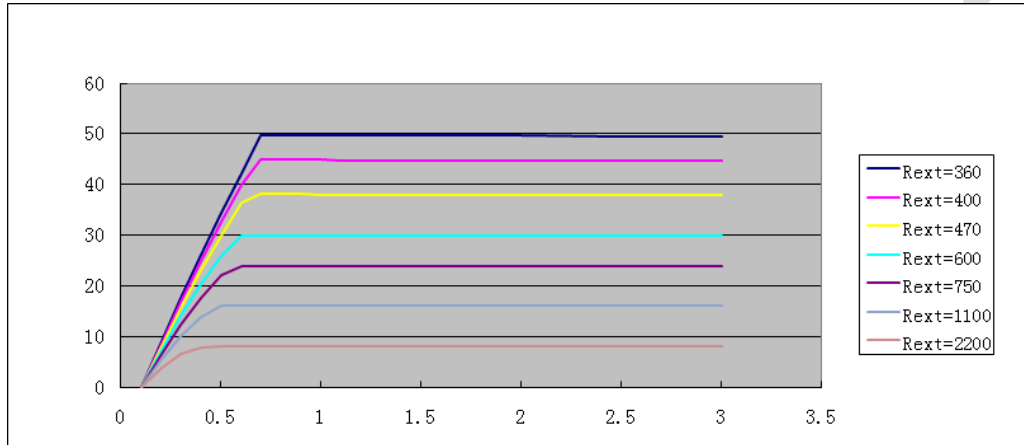

## Setting Output Current

The output current ( $I_{out}$ ) of ICN2053 is set by an external resistor,  $R_{ext}$ . The relationship between  $I_{out}$  and  $R_{ext}$  is :

$$V_{R-EXT} = 1.232V;$$

$$I_{out} = (V_{R-EXT} / R_{ext}) * 7.5$$

**Package Outline**

SSOP24-P-150-0. 635

**SSOP24 (150mil) PACKAGE OUTLINE DIMENSIONS**

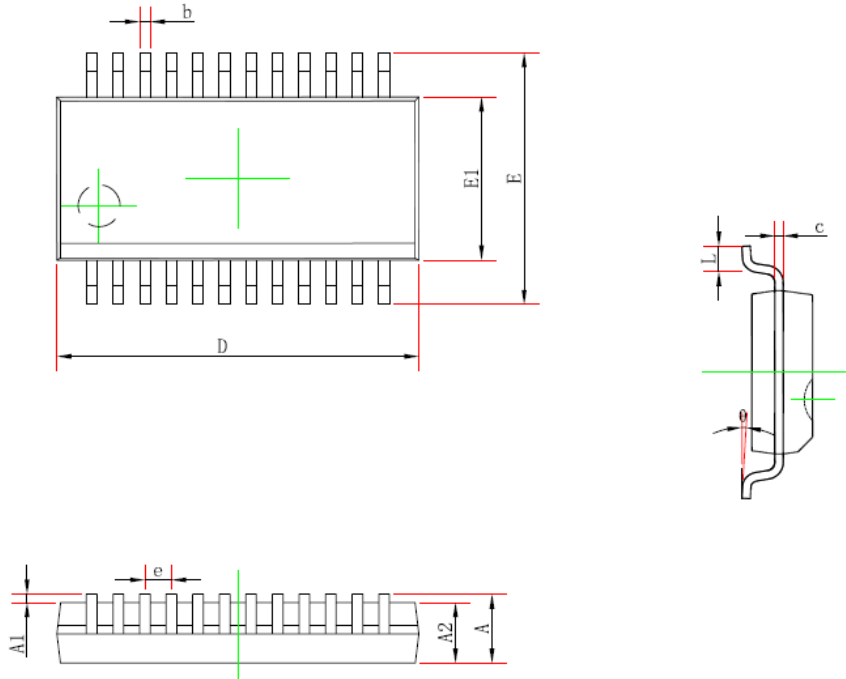

Symbol	Dimensions In Millimeters		Dimensions In Inches	
	Min	Max	Min	Max
A	—	1.750	—	0.069
A1	0.100	0.250	0.004	0.010
A2	1.250	—	0.049	—
b	0.203	0.305	0.008	0.012
c	0.102	0.254	0.004	0.010
D	8.450	8.850	0.333	0.348
E1	3.800	4.000	0.150	0.157
E	5.800	6.200	0.228	0.244
e	0.635 (BSC)		0.025 (BSC)	
L	0.400	1.270	0.016	0.050
θ	0°	8°	0°	8°

## Product Ordering Information

Product number	Package (Pb-Free)	Weight (mg)
ICN2053BP	SSOP24-0.635	130

## Important information

Chipone Technology (Beijing) Co., Ltd. (Chipone) reserves the right to make changes to their products or to discontinue any product or service without notice, and advise customers to obtain the latest version of relevant information to verify, before placing orders, that information being relied on is current and complete. All products are sold subject to the terms and conditions of sale supplied at the time of order acknowledgement, including those pertaining to warranty, patent infringement, and limitation of liability.

Chipone warrants performance of its semiconductor products to the specifications applicable at the time of sale in accordance with Chipone's standard warranty. Testing and other quality control techniques are utilized to the extent Chipone deems necessary to support this warranty. Specific testing of all parameters of each device is not necessarily performed, except those mandated by government requirements.

**CERTAIN APPLICATIONS USING SEMICONDUCTOR PRODUCTS MAY INVOLVE POTENTIAL RISKS OF DEATH, PERSONAL INJURY, OR SEVERE PROPERTY OR ENVIRONMENTAL DAMAGE (“CRITICAL APPLICATIONS”). CHIPONE SEMICONDUCTOR PRODUCTS ARE NOT DESIGNED, AUTHORIZED, OR WARRANTED TO BE SUITABLE FOR USE IN LIFE-SUPPORT DEVICES OR SYSTEMS OR OTHER CRITICAL APPLICATIONS. INCLUSION OF CHIPONE PRODUCTS IN SUCH APPLICATIONS IS UNDERSTOOD TO BE FULLY AT THE CUSTOMER'S RISK.**

In order to minimize risks associated with the customer's applications, adequate design and operating safeguards must be provided by the customer to minimize inherent or procedural hazards.

Chipone assumes no liability for applications assistance or customer product design. Chipone does not warrant or represent that any license, either express or implied, is granted under any patent right, copyright, mask work right, or other intellectual property right of Chipone covering or relating to any combination, machine, or process in which such semiconductor products or services might be or are used. Chipone's publication of information regarding any third party's products or services does not constitute Chipone's approval, warranty or endorsement thereof.

Copyright ©2015, Chipone Technology (Beijing) Co., Ltd.